

TECHNICAL DATASHEET

Absolute Encoder AD58



- For brushless servo motors
- All-digital and highspeed
- +120°C operating temperature
- 10,000 rpm continuous operation
- Optical encoder with a true geared multiturn
- Interface: SSI, BiSS-B or BiSS-C
- Option Sinewave 1 Vpp: Harmonic distortion less than 1%
- Bandwidth 500 kHz

ACURO®
industry

BiSS
INTERFACE

SSI

CE

UK
CA

UL
LISTED

RoHS

The AD58 is an absolute encoder with a true geared Multiturn and optical sensing technology: The mechanical design consists of two ball bearings and a flexible torque support. The AD58 is ideally suited for integration into BLDC servo motors for demanding Applications such as CNC precision machining and printing in professional quality. Through its low current consumption the AD58 is contributing to lowering cost of ownership.

Fully digital control loop

The new and completely digital OptoAsic technology enables the transition to a truly digital drive system. The conventional absolute encoders still have analog sine wave signals for the feedback of speed and position data. The AD 58, however, provides fully digital position data up to 22 Bit (Singleturn) and 12 Bit (Multiturn) over the BiSS interface with a variable clock rate up to 10 MHz. This corresponds a singleturn resolution of more than 4 million measured steps.

TECHNICAL DATA mechanical

Housing diameter	58 mm
Shaft diameter	10 mm (Tapered hollow shaft) 10 mm (Tapered solid shaft) 10 mm / 12 mm (Hollow shaft)
Flange (Mounting of housing)	Tether
Protection class shaft input (EN 60529)	IP40
Protection class housing (EN 60529)	IP50
Axial endplay of mounting shaft (hubshaft)	±0.5 mm
Radial runout of mating shaft (hubshaft)	±0.1 mm
Max. speed	10,000 rpm (continuous) 12,000 rpm (short term)
Starting torque typ.	≤ 1 Nm
Moment of inertia	ca. 3.8 x 10 ⁻⁶ kgm ²
Operating temperature	-15 °C ... +120 °C
Storage temperature ¹	-15 °C ... +85 °C
Vibration resistance (DIN EN 60068-2-6)	100 m/s ² (10 - 2000 Hz)
Shock resistance (DIN EN 60068-2-27)	1000 m/s ² (6ms)
Weight	ca. 260 g (ST) / 310 g (MT)
Connection	PCB connector, 12 / 14 pole

¹due to packing

subject to errors and changes

Datasheet	© Hengstler GmbH Umlandstr. 49 D-78554 Aldingen/ Germany ☎ +49 74 24 - 89 0 Fax +49 74 24 - 89 500	Page
Version 3 081123 TK	E-mail: info@hengstler.com Internet: www.hengstler.com	1/6

TECHNICAL DATASHEET

Absolute Encoder AD58

TECHNICAL DATA electrical

Supply voltage	DC 5 V \pm 10 % or DC 10 - 30 V
Current w/o load typ.	100 mA (ST), 150 mA (MT)
Resolution singleturn	12 - 22 Bit
Resolution multiturn	12 Bit (max. resolution 34 Bit)
Output code	Binary, Gray
Incremental signals	Sine-Cosine 1Vpp
Number of pulses	2048
3dB limiting frequency	500 kHz
Absolute accuracy typ.	\pm 35"
Repeatability typ.	\pm 7"
Parametrization	Resolution, Code type, Direction, Warning, Alarm
Alarm output	Alarm bit (SSI-Option), warning and alarmbit (BiSS)

ELECTRICAL CONNECTIONS

PCB-connector, 12 pole

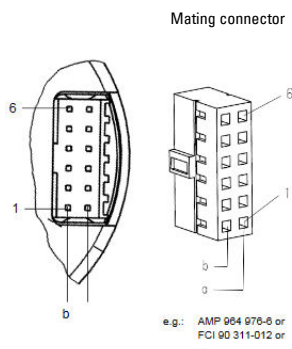

PCB-connector, 14 pole

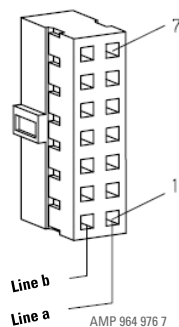

Colour	PIN	Signals
violet	1a	Data/
green	2a	A+
brown/green	3a	0 V Sensor
blue	4a	B+
brown	5a	Clock/
red/blue	6a	5 V Sensor
green/pink	1b	DC 5 V / 7-30 V
white	2b	Clock
red	3b	B-
white/green	4b	0 V (UN)
yellow	5b	A-
black	6b	Data

Colour	PIN	Signals
brown	1a	Data/
yellow	2a	A+
brown/green	3a	0 V Sensor
pink	4a	B+
red	5a	Clock/
violet	6a	5 V Sensor
red/blue	7a	Error/
green/pink	1b	DC 5 V / 7-30 V
black	2b	Clock
blue	3b	B-
grey	4b	0 V (UN)
white/green	5b	A-
green	6b	Data
white	7b	DIR/

subject to errors and changes

TECHNICAL DATASHEET

Absolute Encoder AD58

DIMENSIONED DRAWINGS Tapered solid shaft 1:10

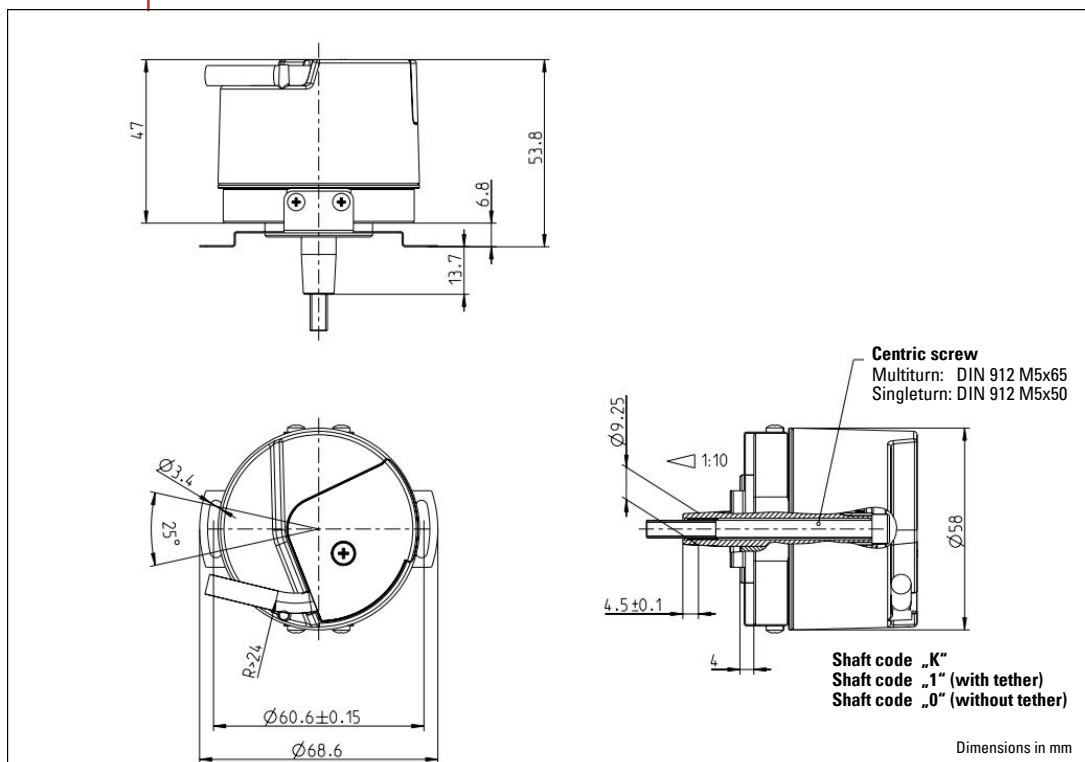

DIMENSIONED DRAWINGS Hollow shaft (straight)

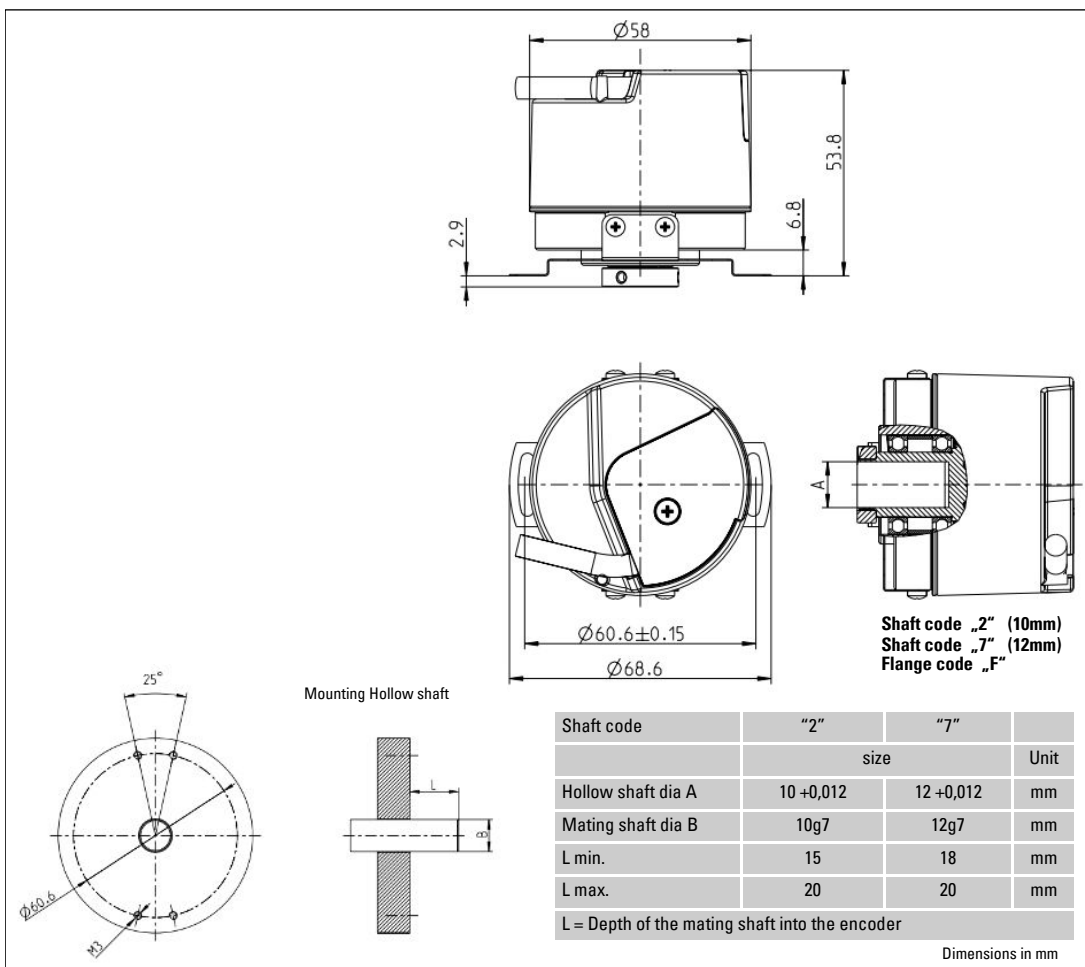

subject to errors and changes

TECHNICAL DATASHEET

Absolute Encoder AD58

**DIMENSIONED
DRAWINGS**
Tapered hollow shaft 1:10

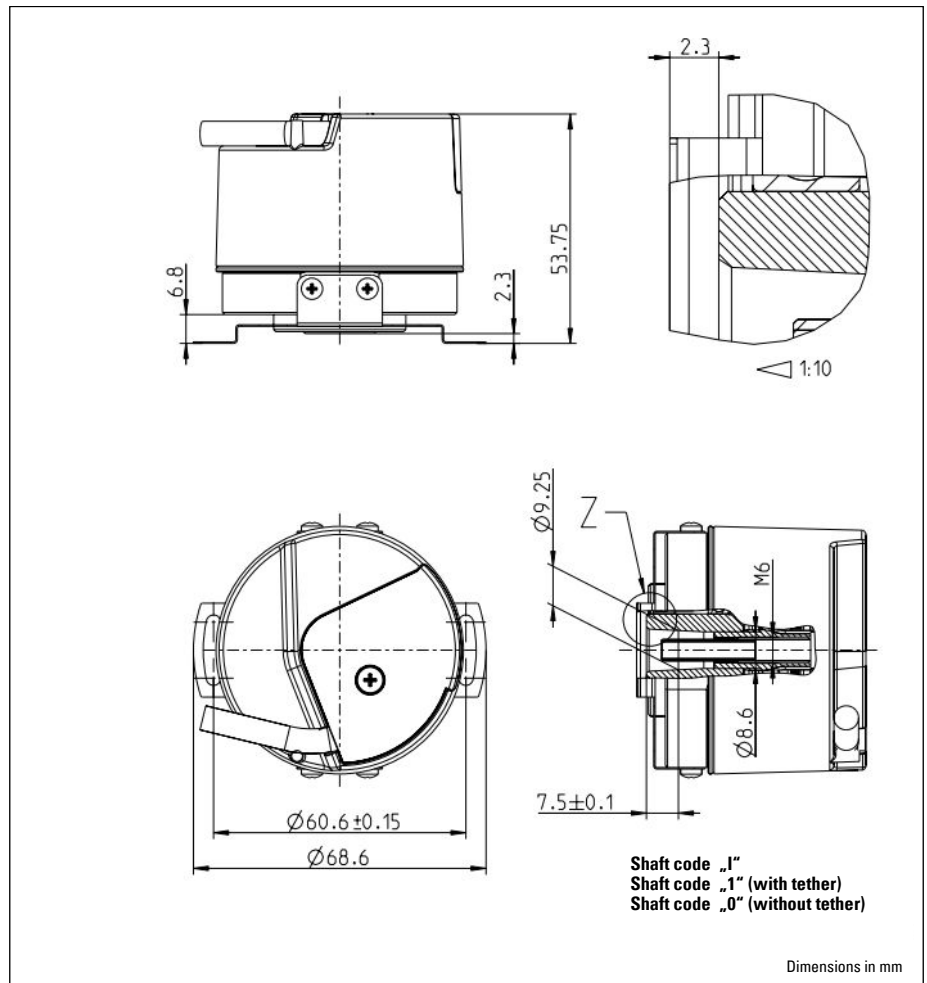

subject to errors and changes

Datasheet	© Hengstler GmbH Umlandstr. 49 D-78554 Aldingen/ Germany ☎ +49 74 24 - 89 0 Fax +49 74 24 - 89 500 E-mail: info@hengstler.com Internet: www.hengstler.com	Page
Version 3 081123 TK		4/6

TECHNICAL DATASHEET

Absolute Encoder AD58

ORDERING INFORMATION

Type	Resolution	Supply voltage ¹	Flange, Protection, Shaft	Interface	Connection
<input type="checkbox"/>	<input type="checkbox"/>	<input type="checkbox"/>	<input type="checkbox"/>	<input type="checkbox"/>	<input type="checkbox"/>
AD58	0012 12 Bit ST 0013 13 Bit ST 0017 17 Bit ST 0019 19 Bit ST 0022 22 Bit ST 1212 12 Bit MT + 12 Bit ST 1213 12 Bit MT + 13 Bit ST 1217 12 Bit MT + 17 Bit ST 1219 12 Bit MT + 19 Bit ST 1220 12 Bit MT + 20 Bit ST 1222 12 Bit MT + 22 Bit ST Others on request	A DC 5 V ² E DC 10-30V	1.0K Spring tether, IP40, Tapered solid shaft 1:10 F.02 Spring tether, IP40, Hollow shaft 10 mm with Clamping ring F.07 Spring tether, IP40, Hollow shaft 12 mm with Clamping ring	BC BISS-B (+ SinCos 1Vpp) BV BISS-C (+ SinCos 1Vpp) SC SSI Gray (+ SinCos 1Vpp) SD SSI Binary (+ SinCos 1Vpp)	0 PCB Connector, axial, 12-pole B PCB Connector, radial, 12-pole, with mating connector + 0,5m cable 1 PCB Connector, axial, 14-pole

¹The encoder is designed to be connected to a SELV power supply. A connection to a DC voltage network is only permitted with the appropriate protective circuit. A corresponding EMC protective circuit is generally required for cable lengths > 30 m .

²With a 5V supply there is no reverse polarity protection

subject to errors and changes

TECHNICAL DATASHEET

Absolute Encoder AD58

Accessories

CONNECTION CABLE

Article	Length (m)	Part.-Nr.
Cable 12 pole	0,5 m	1 547 049
Cable 14 pole	0,5 m	1 548 003

TETHER

Article	Part.-Nr.
Spring tether (for all Flange types)	E1 547 045

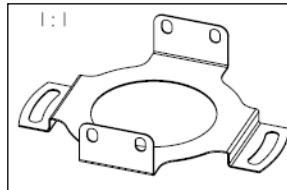

COVER

Article	Part.-Nr.
Cap with screws (Cover)	E1 547 295

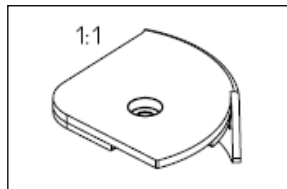

subject to errors and changes