

tico 772/773/774





Multifunctional counter tico 772/773/774

- Universally applicable as a tachometer, timer, shift counter, batch counter ...
- Easy to operate
- Four different backlight colours
- Intensity of backlighting can now be adjusted
- Large, clearly readable 48 x 48 mm display
- Input frequency up to 60 kHz
- Easy installation via plug-in terminals
- Three presets

TECHNICAL DATA

GENERAL

Display	LCD reflective, Transflective positive: black figures on backlit background Transmissive negative: white, red or green figures on backlit ground, 2 lines, 6-digit counter readings & presets; leading zero suppression, decimal point (up to 4 decimal places)
Digit height	1st line 9.3 mm; 2nd line 7.2 mm
Supply voltage	SELV: 12-30 VDC; reverse polarity protected SELV: 24 VAC, 50/60 Hz \pm 10% 115 VAC; 230 VAC, 50/60 Hz \pm 10% 100-240 VAC 50/60 Hz \pm 10% with switch-mode power supply
Current consumption	12-30 VDC <200 mA, 12-30 VDC <250 mA with backlight 24 VAC <250 mA; including sensor supply 115/230 VAC <50 mA; including sensor supply 90 VAC max. 80 mA; including sensor supply with switch-mode power supply
Power consumption	<5 W <8 W with switch-mode power supply
Duty cycle	100%
Overload protection	External fuse DC: 0.16 AT (IEC 127); DC: 0.2 AT (UL 198) 24 VAC: 315 mAT; 230 VAC: 32 mAT; 115 VAC: 63 mAT
Overload protection	External fuse 230 V, 2.5 mAT
Relay outputs	DC: 0.16 AT (IEC 127); DC: 0.2 AT (UL 198) 24 VAC: 315 mAT 230 VAC: 32 mAT; 115 VAC: 63 mAT
Sensor supply	Transformer: AC operation: 12-24 VDC (load dependent), max. 50 mA Switch-mode power supply: AC operation: 24 VDC/-5%, max. 115 mA max. capacitive load = 470 μ F
Data storage	Non-volatile memory >10 years
Electrical connection	Plug-in screw-type connections/terminals
Wire cross-section	1-1.5 mm ² with wire-end sleeves

Amplitude threshold	<2 V and >8 V or <1 V and >4 V at TTL level, Amplitude max. 40 VDC	
Active edge	Programmable positive for PNP input, negative for NPN input	
Input resistance	Approx. 10 kOhm	
Count frequency	Max. 60 kHz; 30 Hz attenuated max. 20 kHz; 30 Hz attenuated in TTL operation Application input max. 6 kHz/30Hz attenuated To prevent the maximum input frequency of 60 kHz being exceeded, the following maximum input frequencies apply: Phase discriminator, single evaluation: A and B, each 30 kHz (20 kHz) TTL Phase discriminator, double evaluation: A and B, each 30 kHz (20 kHz) TTL Phase discriminator, quad evaluation: A and B, each 15 kHz (15 kHz) TTL Single-channel metering & directional input: input A 60 kHz (20 kHz) TTL Differential metering, totalizing: input A + B 60 kHz (20 kHz) TTL If the application input is also used as a metering input: Single-channel metering & directional input: input A + app. input 60 kHz (20 kHz) TTL Differential metering, totalizing: input A + B + app. input 60 kHz (20 kHz) TTL  ->refer to graph on Page 5	
Pulse wave shape	Any (at max. frequency, square 1:1)	
Pulse duration min.	17 ms (30 Hz); 8 µs (60 kHz)	
Prescaler	0.0001-99.9999	
Reset	Manual reset via keyboard, external static or dynamic reset, min. pulse length 5 ms, automatic reset after reaching Preset 2. No pulse losses at max. counter frequency due to automatic reset function. Via programmable application input and programmable power-on reset	
Set function	Setting to Preset 0 (independent of reset)	
Display and preset range	-999,999 to +999,999	
Alarm signal	Display flashes when preset 0, 1 or 2 is active	
Signal times	0.01 s to 599.99 s or bistable programming; tolerance ± 10 ms; active on or off	
Relay (Presets 1 and 2)	Change-over contact max.: 250 VAC/30 VDC/5 A Change-over contact min.: 5 VAC/5 VDC/10 mA; delay <10 ms	
Transistor output (Presets 1 + 2)	PNP output	12-30 VDC, max. 50 mA for DC supply 12-24 VDC, max. 30 mA for AC supply 24 VDC, max. 50 mA for AC supply with switch-mode power supply
Application output	PNP output	12-30 VDC, max. 20 mA for DC supply 12-24 VDC, max. 20 mA for AC supply 24 VDC, max. 20 mA for AC supply with switch-mode power supply 
AC transformer only	Combined current load of outputs (sensor 12-24 VDC, Out1, Out2, app. output) must not exceed 65 mA.	

tico 772/773/774

Multifunctional counter tico 772/773/774

COUNTER

Counter mode Input A,B	Unidirectional; adding or subtracting; directional input; Differential operation, add/sub; totalizing add/add; phase discriminator single, double or quadruple evaluation
Control input	Reset, gate
Preselect modes	Absolute or trailing, range signal/ limit values (signal 1 <P1, signal 2 >P 2)
Application input/output	Output: prescaler out, preset 0 out, direction out Input: additional counter input add/sub, reset, set, gate, keylock, hold, teach in

BATCH COUNTER

Mode	Batch counter with preset or 2nd totalizer with preset
------	--

SHIFT COUNTER

Counter mode of operation	Differential counting add/sub, totalizing add/add
------------------------------	---

TACHOMETER

Measuring principle	Period (cycle) measurement (1/tau)
Time base	1/min or 1/s
Min. frequency	1 Hz or 0.1 Hz
Limit values	2 alarms with programmable startup suppression + 1 additional upper limit value on the application output
Tachometer mode of operation	Unidirectional add/sub; directional input Differential add/sub; totalizing add/add; Phase discriminator single, double or quadruple evaluation A/B or (A-B)/A%
Application input/output	Output: Preselect 0 out, direction out Input: Additional counter input add/sub, keylock, hold, teach in
Accuracy of the tachometer function	Time base: ± 30 ppm Measuring principle: cycle duration measurement Measuring time: min. 0.5s/max. 1s or 10s Measuring resolution: 0.4µs (<30 ppm) Display resolution: 4 decimal places, 1 digit = 100 ppm
Overall tolerance	= displayed resolution + tolerance of timebase = 130 ppm

TIMER

Measuring principle	Pulse-width or cycle duration measurement Start input A + Stop input B; Start/Stop key
Time base	Programmable in sec, min, h or hh.mm.ss
Resolution	1; 0.1; 0.01; 0.001; 0.0001
Function	Single-pulse or cumulative measurement
Application input/output	Output: preset 0 out, Input: additional run, stop, reset, set, keylock, hold, teach in

tico 772/773/774

Multifunctional counter tico 772/773/774

ENVIRONMENTAL REGULATIONS, SAFETY PROVISIONS

Accuracy of the timer	Time base: ± 30 ppm Start/Stop-point in time: 16 μ s/16 ms (not damped/damped) Resolution: 100 μ s = 100 ppm
Overall tolerance	= Displayed resolution + tolerance of timebase = 130 ppm

Safety provisions	EN 61 010-1/IEC 61010-1
Protection class	II; EN 61010-1/IEC 61010-1
Pollution degree	V 2, EN 50178
EMC interference compatibility	EN 61326-1 industrial environment**
EMC emissions	EN 61326-1 Class B**
Ambient temperature	0°-50°C EN 60 068-2-1/2
Storage temperature	-20° to +65°C EN 60 068-2-1/2
Climate	40°C/93% rel. humidity class 4K4H, EN 60 068-2-78 25-50°C/93% rel. humidity cyclical, EN 60 068-2-38
Ingress protection	IP 65 front; EN 60529 IP 20 terminals
Vibration resistance	10 m/s ² (10 to 150 Hz); IEC 60 068-2-6
Shock resistance	100 m/s ² (18 ms); IEC 60 068-2-27
Resistance to chemicals	Front film to DIN 42 115-2
Approvals	UL
RoHS	Compliant

PHYSICAL DATA

Installation	Front-panel installation with tenter (frame) Front panel thickness max. 11 mm
Dimensions	In accordance with DIN 43700, 48 mm x 48 mm x 118 mm, installation depth 110 mm
Front-panel cutout	45 mm x 45 mm + 0.3 mm
Weight	Approx. 200 g

** For cable lengths >30 m, connection to DC supply and input level TTL, additional protective circuits will be necessary.

COUNTING FREQUENCY AS A FUNCTION OF SIGNAL VOLTAGE

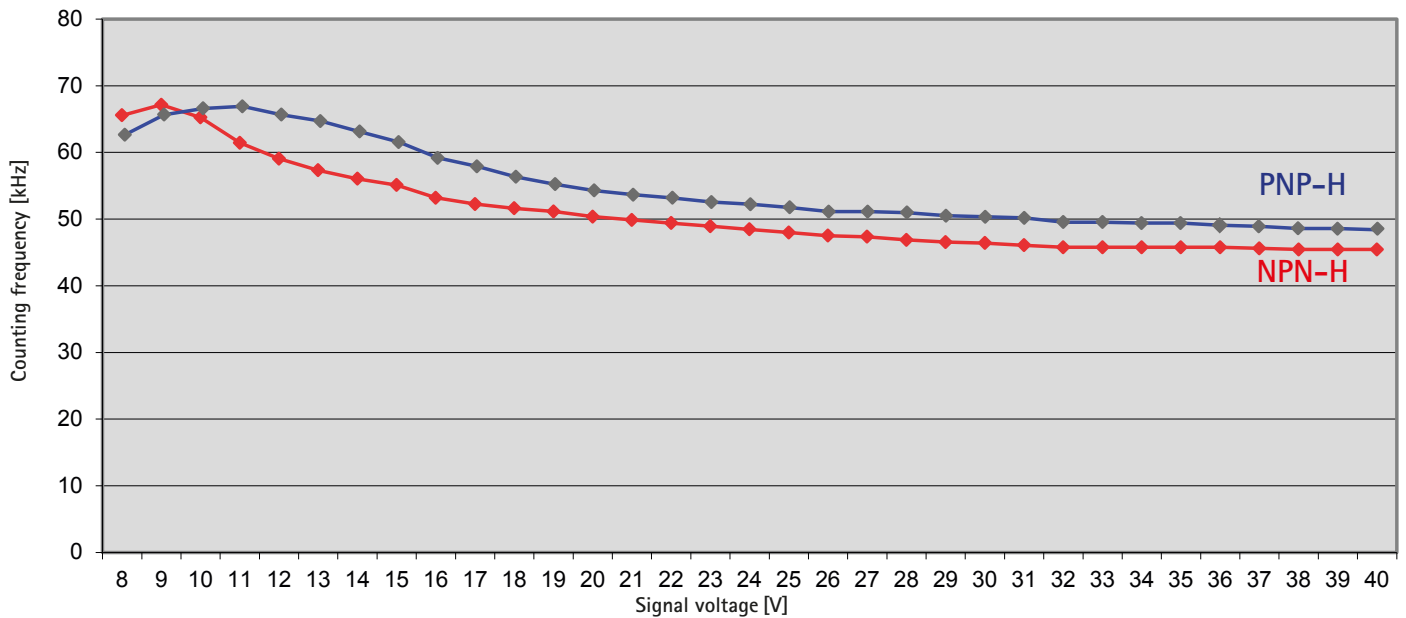

The counting frequencies were determined using a signal generator with an output resistance of 50 ohms.

DIMENSIONED DRAWINGS

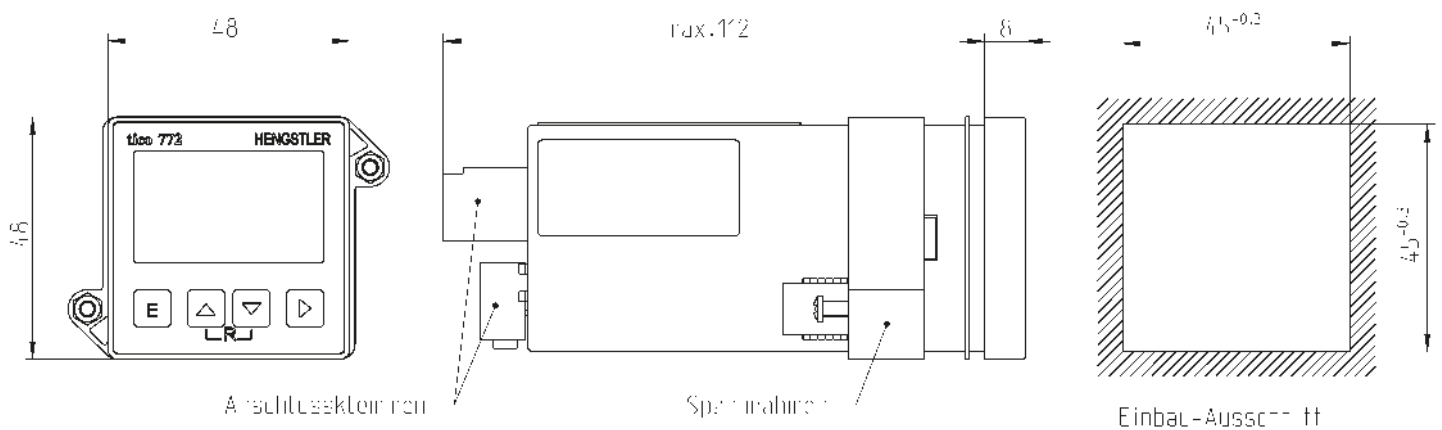

CONNECTION OPTIONS

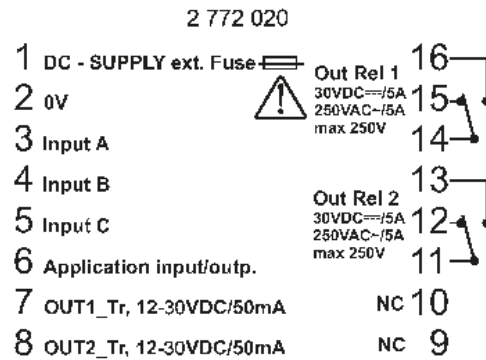

VDC 2 relays/2 transistors

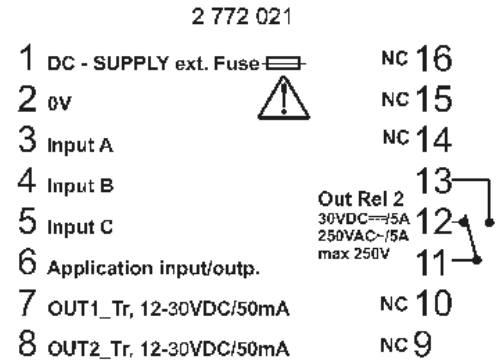

VDC 1 relay/2 transistors

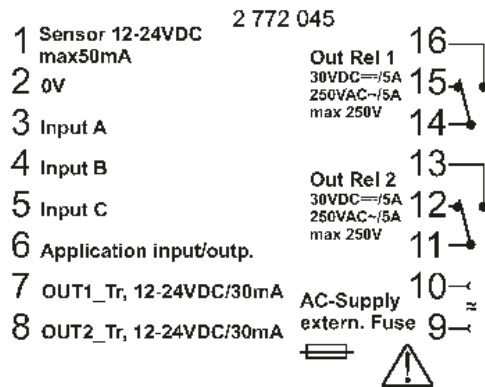

VAC Transformer 2 relays/2 transistors

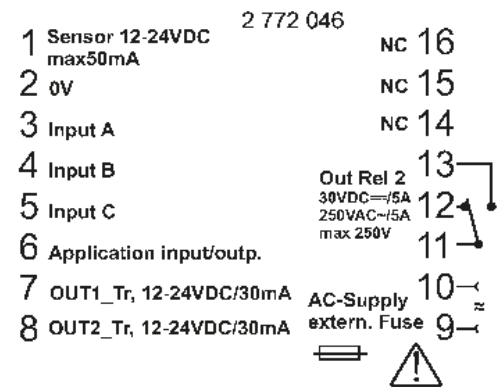

VAC Transformer 1 relay/2 transistors

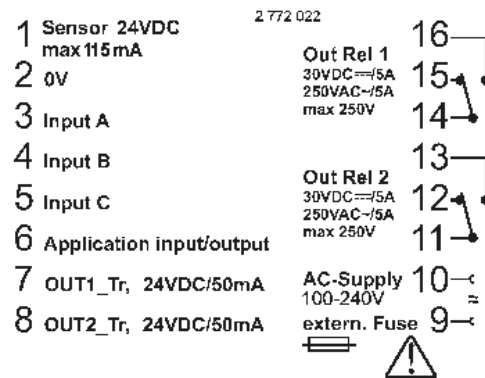

VAC Switch-mode power supply
2 relays/2 transistors

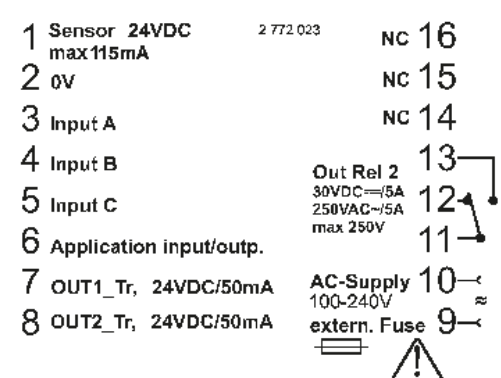

VAC Switch-mode power supply
1 relay/2 transistors

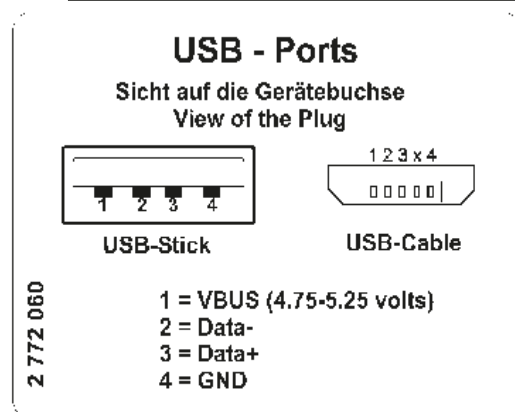

USB interface on Tico 773

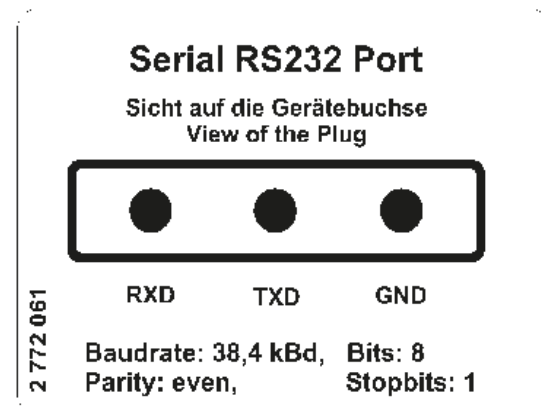

RS232 interface on Tico 774

ORDER INFORMATION

Display	Relays	12-30 VDC	24 VAC	115 VAC	230 VAC	100-240 VAC
---------	--------	-----------	--------	---------	---------	-------------

Tico 772

LCD reflective	1	0 772 101	0 772 111	0 772 121	0 772 131	0 772 141
LCD reflective	2	0 772 102	0 772 112	0 772 122	0 772 132	0 772 142
Transmissive negative	1	0 772 301	-	-	-	0 772 341
Transmissive negative	2	0 772 302	-	-	-	0 772 342
Transmissive red	1	0 772 401	-	-	-	0 772 441
Transmissive red	2	0 772 402	-	-	-	0 772 442
Transmissive green	1	0 772 501	-	-	-	0 772 541
Transmissive green	2	0 772 502	-	-	-	0 772 542

Tico 773 with USB port

LCD reflective	1	0 773 101	-	-	-	0 773 141
LCD reflective	2	0 773 102	-	-	-	0 773 142
Transmissive negative	1	0 773 301	-	-	-	0 773 341
Transmissive negative	2	0 773 302	-	-	-	0 773 342
Transmissive red	1	0 773 401	-	-	-	0 773 441
Transmissive red	2	0 773 402	-	-	-	0 773 442
Transmissive green	1	0 773 501	-	-	-	0 773 541
Transmissive green	2	0 773 502	-	-	-	0 773 542

Tico 774 with RS232 port

LCD reflective	1	0 774 101	-	-	-	0 774 141
LCD reflective	2	0 774 102	-	-	-	0 774 142
Transmissive negative	1	0 774 301	-	-	-	0 774 341
Transmissive negative	2	0 774 302	-	-	-	0 774 342
Transmissive red	1	0 774 401	-	-	-	0 774 441
Transmissive red	2	0 774 402	-	-	-	0 774 442
Transmissive green	1	0 774 501	-	-	-	0 774 541
Transmissive green	2	0 774 502	-	-	-	0 774 542

Transmissive negative: white figures on a dark background

Transmissive red: red figures on a dark background

Transmissive green: green figures on a dark background